

**DIAVITE DH-8 & COMPACT II**

# ROUGHNESS MEASUREMENT SYSTEM

# DIAVITE – HIGH PRECISION WITH DH-8 & COMPACT II

## HIGH PRECISION SURFACE ROUGHNESS METER

Universal use in workshop and inspection room, integral thermo printer for all measuring values, profile and bearing ratio. Automatic print out after each measurement possible. Memory for measurements. Choice of many types of tracers to realize more measuring tasks. User friendly comprehensive multilingual menu guidance. Tolerance indication for exceeded limits of measuring values. From the simple roughness measurement without accessories, directly on the machine, over measurements in the laboratory with measuring support, special tracers and further accessories, up to the recording of contours, the **DIAVITE DH-8** and **COMPACT II** offers the maximum of flexibility allowing judging the quality of surfaces.

## ROUGHNESS TRACERS (PROBES)

The tracers are the heart pieces of the roughness meters, they are, to a wide extent the determining factor of the precision of the measuring values obtained. The great choice of tracers enables us to solve measuring tasks previously believed unsolvable, are the result of decades of experience in the construction of such probes. The traversing unit with an integrated reference flat also allows to effect precise measurements also with skid less tracers and to render possible the flexible use of this equipment.

## FLEXIBILITY

The **DIAVITE DH-8** and **COMPACT II** are not only a roughness meter suitable for use in the workshop. Combined with its choice of software programmes, it is perfectly capable to solve selective high level measuring tasks in the laboratory. The suitable variety of accessories is an ideal support to fulfil the daily measuring.

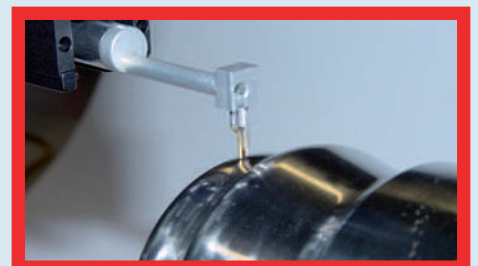
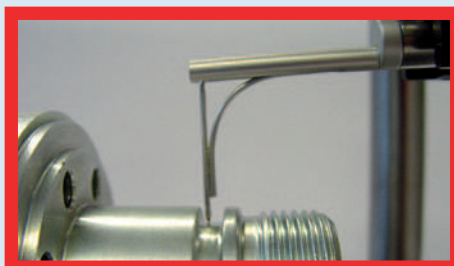

**LINEARITY AND MEASURING ACCURACY**

Since 1995, the analogue Hall-effect-technology with a high linear output signal, employed for the first time by **DIAVITE**, has proven its superiority against previously incorporated systems. With this technique, high linearity over the average is reached. On the display bar, an arrow now indicates the exact definition of the green phase for an optimal positioning of the diamond point and thereby allows to effect skid less tracer-measurements with **DH-8** and **COMPACT II** even more precisely. The **DH-8** and **COMPACT II** has moved positively from an ordinary workshop instrument in the direction of a higher-class versatile surface roughness meter.

**TRACERS**

The flexible application of a surface roughness meter can be reached by a multiple choice of tracers only. For **DH-8** and **COMPACT II**, 15 different tracers are at disposal, and thanks to the integrated reference flat in the traversing unit VHF, very precise measurements are no longer a problem even using skid less tracers. The suitable accessory is completing the **DH-8** and **COMPACT II** ideally and allows measurements of very small parts too.

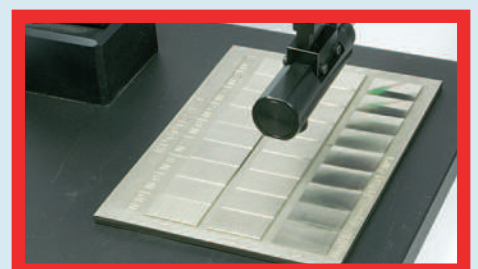
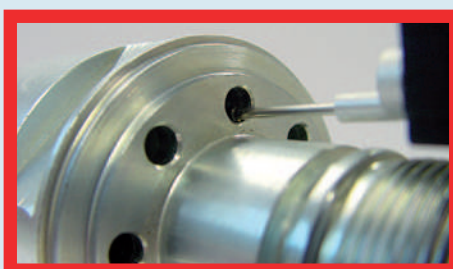
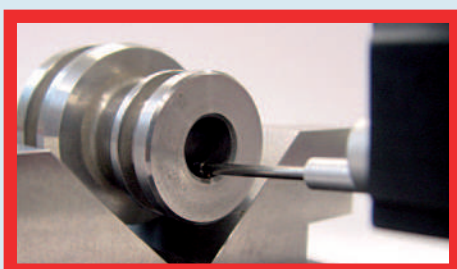
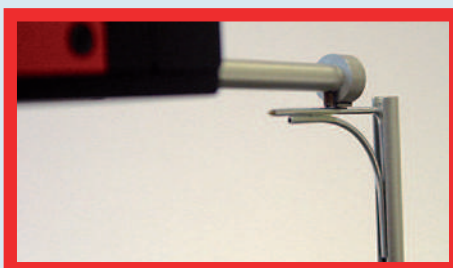
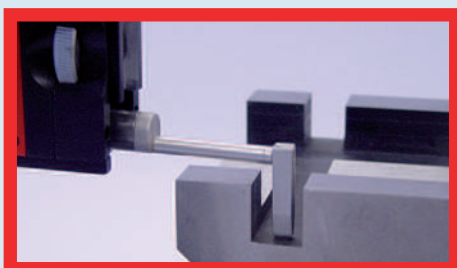

# COMPACT II – SIMPLE RELIABLE AND ADAPTABLE

## ROUGHNESS MEASUREMENT

- › Measuring- and indicator unit with graphic display and four function buttons
- › Traversing unit VH for tracers with skid or traversing unit VHF for tracers with and without skid
- › Traversing unit integrated in the instrument, can also be connected with a cable to the instrument (option for VH) for measurement with stand or to reach difficult measuring points
- › Cut-off firmly assigned to the traversing length
- › Memory for 15 measuring profiles
- › Automatic calibration
- › Data output USB interface
- › Data transfer to PC for further processing in optional software **DIASOFT**
- › Rechargeable battery for mobile applications
- › Accuracy same as for **DIAVITE DH-8** thanks to the application of the same traversing units and the same tracers



Software, tracers and accessories for the **DIAVITE COMPACT II** see page 6 and more

## SCOPE OF SUPPLY

- › Instrument COMPACT II
- › Motor unit VH or VHF
- › Standard tracer SH
- › Adapter with connecting cable
- › Specimen metal Ra = 3.00
- › Charger
- › USB-connecting cable
- › Screwdriver
- › Instruction manual + short manual
- › Certificat of quality
- › Carrying case
- › Software DIASOFT Basic

# DH-8 – EXPANDABLE FOR CONTOUR AND OPTIC



## SURFACE ROUGHNESS MEASUREMENT

- › High precision surface roughness meter for universal use in workshop and inspection room
- › Automatic calibration
- › Memory for 50 measurements
- › 5 measuring length, all selectable between 0.5 and 15.0 mm
- › Measuring speed selectable
- › Calibration for max. 8 tracers
- › 8 measuring programs
- › Choice of many types of tracers to solve nearly all measuring tasks, also customer specific ones
- › User friendly comprehensive multilingual menu guidance
- › Tolerance indication for measuring values exceeding permissible allowance set
- › Key lock for Lt, Lc and R to prevent any settings being changed by mistake during measuring procedure
- › USB output for data transfer (option: Bluetooth)

## SCOPE OF SUPPLY

- › Instrument DH-8
- › Motor unit VH or VHF
- › Standard tracer SH
- › Specimen metal Ra = 3.00
- › Charger
- › Connecting cable
- › USB-connecting cable
- › Screw driver
- › Instruction manual + short manual
- › Certificate of quality
- › Carrying case
- › Software DIASOFT Basic

- › Choice of capable software programmes DIASOFT (optional)
- › Numerous accessories for many applications, needed for working with skidless tracers

## OPTIONS FOR DH-8

### MEASUREMENT OF CONTOURS

The **DH-8** now offers, as an option, to precisely measure contours. For this purpose, a special contour measuring tracer is needed, in combination with a special software.

### CHARACTERISTICS

- › Measuring range X: from 0.5 to 15.0 mm
- › Measuring range Z: max. 4 mm
- › Tracing angle: falling flanks up to 88° rising flanks up to 77°

## OPTICAL MEASUREMENT

Measurement of more surfaces: vertical steps, high aspect ratios, bumps and holes, fragile, soft, flexible, sharp, hard or abrasive surfaces, transparent, reflective, opaque, multi-material surfaces

## CHARACTERISTICS

- › Measuring head: CLA-400
- › Measuring range Z: 400 µm
- › Working distance: 5 mm
- › Repeatability: 2 nm
- › Vertical resolution: 0.025 nm
- › Spot size: 7 µm
- › Maximum slope: ±30°

Software, tracers and accessories for the **DIAVITE DH-8** see page 6 and more. Please ask for Contour and Optic.

# DIASOFT – VISUALISE YOUR MEASURES

## PC-SOFTWARE PROGRAM «DIASOFT»

The software as a supplement and extension of **DIAVITE** includes further roughness parameters and can present and memorize profiles. These can be analysed and compared with each other. This software is available in 4 different versions:

### Basic (incl. in the scope of supply)

Basic programmes with Ra, Rq, Rv, Rp, Rt, Sm, Rsk, Rku, Rz, RTp, RHTp, RDq, RPC, roughness curve, Abbott curve

### Standard

Same as «Basic», additionally with waviness and roughness profile on the same curve, zoom functions, symmetry, comparison of profiles and more.

### Automotive

Same as «Standard», additionally with ISO 12085 (CNOMO), ISO 13565, (parameter Rk)

### Expert

Same as «Automotive», additionally analysis of series of profiles and a lot more features to analyse the measurements. The most complete offer for the specialist, now and in future.

## OPTIONS FOR STANDARD, AUTOMOTIVE AND EXPERT

- › Module advanced contour
- › Module simple contour
- › Module statistics

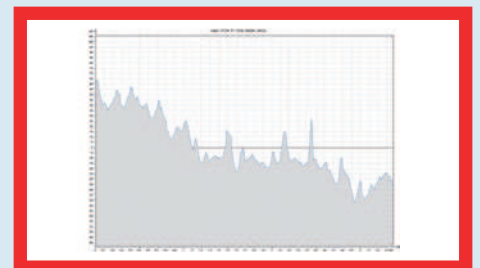
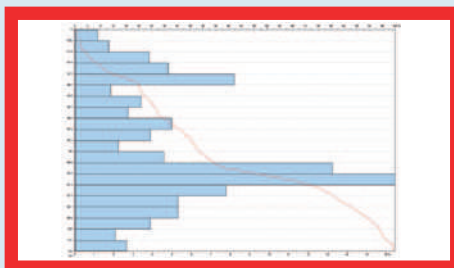
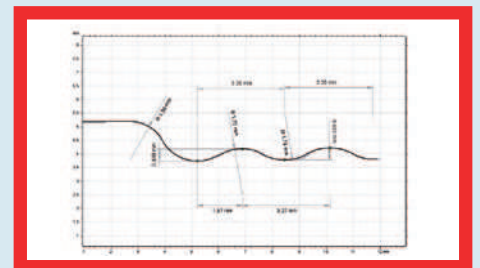
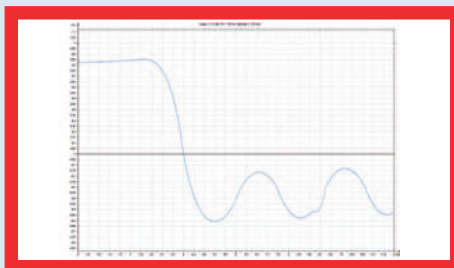

# TRACERS – FOR USE WITH ALL DIAVITE INSTRUMENTS

**TRACER WITH SKID**

(Enumeration not complete)

**Standard tracer**

SH



Smallest bore: Ø 8 mm  
Max. measuring depth: 27 mm  
Included in the delivery

**Bore tracer**

BH



Smallest bore: Ø 2.5 mm  
Max. measuring depth: 20 mm

**Slot tracer**

NH



Max. depth of slot: 15 mm and 20 mm  
Min. width of slot: 3 mm

**Axis and knives tracer**

AH



For measuring small axis, knives, edges and wires

**Concave-convex tracer**

KKH

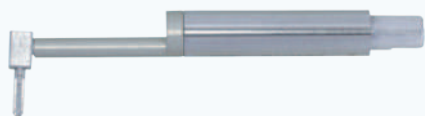

For measuring concave and convex work pieces having a minimum radius of 5 mm. Also irregular curves can be measured.

**Gear tooth flanks tracer**

ZH



Tracer with skid for tooth flanks up to module 2



# TRACER CONTINUATION

## TRACER WITH SKID CONTINUATION

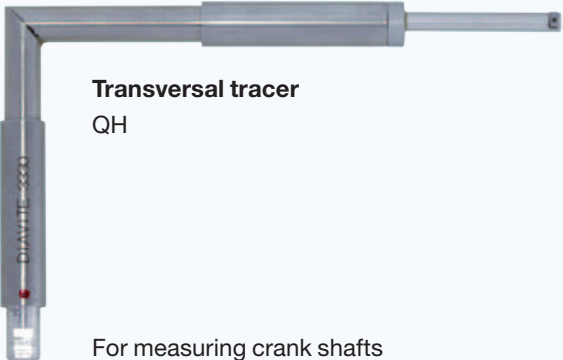
(Enumeration not complete)





**Transversal tracer**  
QH

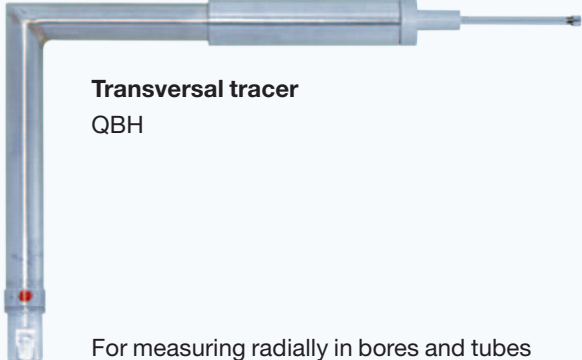

For measuring crank shafts





**Transversal tracer**  
QBH

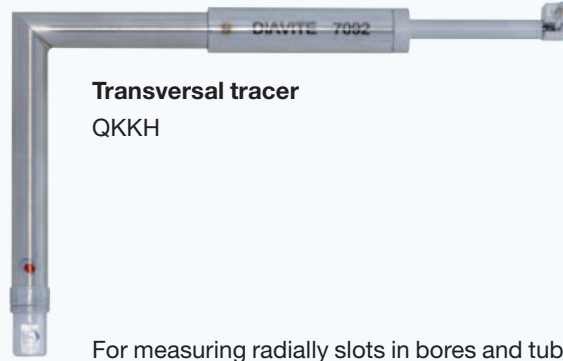

For measuring radially in bores and tubes



**Transversal tracer**  
QKKH



For measuring radially slots in bores and tubes

**Basis tracer**  
TH



For measuring of deep level flats till 140 mm

**Circumference- and ball tracer**  
UH



Minimum possible diameter  $\varnothing$  8 mm





**SKID LESS TRACER**

(Enumeration not complete)

**Bore tracer**  
BZFH



Smallest bore: Ø 1.5 mm  
Max. measuring depth: 15 mm  
Gear tooth flanks: from module 0.75

**Small bore tracer**  
BZFH-06



Smallest bore: Ø 0.8 mm  
Max. measuring depth: 15 mm  
Gear tooth flanks: from module 0.5

**Slot tracer**  
NFH



Max. depth of slot: 25 mm  
Min. width of slot: 1.5 mm

**Slot tracer**  
NFH-06



Max. depth of slot: 10 mm  
Min. width of slot: 1.0 mm

**Axis and knives tracer**  
AFH



For measuring small axis, knives, edges and wires

**Transversal tracer**  
WFH



For measuring slot inside flanks

# ACCESSORIES – SIMPLY FITTED TO ALL INSTRUMENTS

## ACCESSORIES DIAVITE DH-8 AND COMPACT II



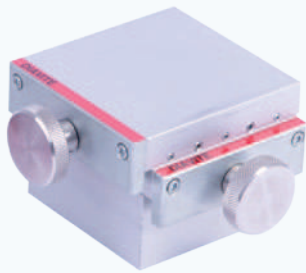

Cross table 70 x 70 mm for the vices



Vices with jaws width 15 mm, 25 mm and 35 mm



Various small supports



Various metal or glass specimen



Device for the manual measurement of crank shafts (without tracer and motor unit)



To extend the tracers for deep bores (up to 700 mm)

TECHNICAL DATA	DIAVITE COMPACT II AND DH-8	
Parameters	<ul style="list-style-type: none"> <li>➤ ISO/DIN: Ra, Rz (DIN), Rmax, R3z, Rt, Rq (RMS), Rk, Rp, Rv, Rpk, Rvk, MR1, MR2, Rpc, C1, C2, percentage contact area, C0, Cz</li> <li>➤ JIS: Ra (JIS), Rz (JIS)</li> <li>➤ ISO 12085: R, AR, Rx</li> <li>➤ additional parameters possible with optional PC software</li> </ul>	
Measuring range	<ul style="list-style-type: none"> <li>➤ Ra, Rq: 0–20.00 µm   0–800 µin</li> <li>➤ All other measuring values: 0–350.0 µm   0–1400 µin</li> </ul>	
Resolution	<ul style="list-style-type: none"> <li>➤ Ra, Rq: 0.001 µm</li> <li>➤ All other measuring values: 0.01 µm</li> </ul>	
Output	USB interface	DH-8: option Bluetooth
Humidity	max. 80 %, not condensing	
Languages	German, English, French, Italian, Spanish, Polish	
Tracing system	Analog hall effect technology with high linearity output signal	
Diamond tip	Radius: 5 µm, 90° (standard) or 2 µm, 60° (option)	
Tracing skid	25 mm (standard tracer)	
Static measuring force	Stylus <0.5 mN	
Static tracking force	Skid <0.15 N	
Tracing speed	COMPACT II: 0.5 mm/s	DH-8: 0.25, 0.5 und 1.0 mm/s
Reverse speed	1.0 mm/s	
Motor unit	VH (tracer with skid) or VHF (all tracers with and without skid)	
Dimensions instrument	COMPACT II: 140 x 75 x 60 mm	DH-8: 245 x 130 x 78 mm
Dimensions motor unit	ca. 20 x 33 x 136 mm (with supporting shoe)	

**Made in Switzerland**

Specifications subject to change without prior notice!

**DIAVITE AG**

**DIAVITE AG**  
Switzerland